

User's Manual
For CL2505
Pulse Type Closed-loop Stepper Driver



Changzhou Fulling Motor Co, Ltd

Add: No.69 KunLun Road, New District, Changzhou City, 213032, China

Tel: +86-519-85132957

Fax: +86-519-85132956

Web site: www.fullingmotor.com

Email: info@fullingmotor.com

All Rights Reserved, No reproduction

Attention: Please read this manual carefully before using the driver!

Contents

I . Product Introduction	2
1. Overview	2
2. Feature.....	2
3. Applications	3
II .Electrical, Mechanical, Environment Specifications	3
1. Electrical specifications	3
2. Operating environment and parameters	3
3. Mechanical installation dimensions diagram	4
4. Heat dissipation considerations	4
III.Driver Interface and Wiring Introduction	4
1. Interface description.....	4
2. Control signal interface circuit.....	5
3. Sequence chart of control signals.....	6
4. Wire connection	7
IV.DIP Switch Configurations	7
V.Brake Motor Connection Method	8
VI. Common Problems and Solutions	8
Product Warranty Terms	9

CL2505

Pulse Type Closed-loop Stepper Driver

I . Product Introduction

1. Overview

CL2505 adopts the latest special motor control DSP chip and optimized closed-loop control technology which can reduce the motor vibration, effectively reduce the motor heating, prolong the motor lifespan through the intelligent regulation of current. The high speed torque attenuation is much lower than that of the ordinary open-loop driver, which can greatly improve the high speed performance and torque utilization rate of the stepper motor, thus improving the efficiency and precision of the machine.

It is very convenient for clients to monitor and control by the Built-in output signals - POSITION, ALARM, BRAKE and to ensure the safe operation of processing equipment by alarm function of position following error. Two groups of 10-bit dial-up can be used for a number of common function settings, including single and double pulses, open and closed loop mode selection, instruction smoothing filter time and so on, which can make debugging more convenient. We are committed to providing customers with cost-effective motor control solutions.

2. Feature

- Input voltage from 24 to 50VDC (36V/48VDC Recommended)
- Continuous output effective current:5.0A (MAX)
- Suitable for 60mm, 86mm series closed-loop stepper motor
- Pulse, Direction, Enable signal input interface level is compatible 5V~24V
- Pulse, Direction, Enable differential signal input, giving consideration to differential, common-anode and common-cathode connection method.
- Maximum pulse frequency of control instruction is 500KHz (Factory default is 200KHz)
- Common-cathode connection method of output signal, alarm, position, Z signal, brake control. The position and Z signal dialing code can be set.
- Micro-step dial switch setting (200-51200) , When all the Micro-step dialing code is

ON, the upper computer can modify any Micro-step at will.

- Single and double pulse, open and closed loop mode selection, smoothing filter time can be set by dialing code.
- With protection functions from over - voltage, under - voltage, over - current and position following error.
- With serial RS232 debugging function, but you need to use our company's dedicated serial debugging cable.
- The latest special motor control DSP chip and optimized closed-loop control technology are adopted for intelligent regulation of current.
- Performance: smooth motion, super-low motor noise, small overshoot, small position following error.

3. Applications

Suitable for medium and small automation machines and equipment, such as electronics manufacturing equipment, 3C non-standard automation equipment, screw machine, peeler machine, winding machine, crimping machine, laser cutters, marking machine, inkjet printers, engraving machines, automatically crawl devices, Special CNC numerical control machine tool, packing devices, robots and so on.

II .Electrical, Mechanical, Environment Specifications

1. Electrical specifications

Parameters	CL2608			
	Min	Typ.	Max	Unit
Continues output current	1	-	5	A
Supply voltage(DC)	24	36/48	50	Vdc
Logic input current	6	10	16	mA
Logic input voltage	4.5	5	28	Vdc
Pulse input frequency	0	200	500	kHz
Isolation Resistance	100	-	-	MΩ
Logic output current	-	-	100	mA
Output hi-pot	-	-	24	Vdc

2. Operating environment and parameters

Cooling		Natural cooling or forced cooling
Operation Environment	Environment	Don't place next to other heating equipment, Avoid dust, oil fog and corrosive gases, excessive humidity and strong vibration, No flammable gas and conductive dust.
	Ambient Temperature	0°C ~ 50°C
	Humidity	40 ~ 90%RH
	Vibration	10 ~ 55Hz / 0.15mm
Storage Temperature		-20°C ~ 65°C
Weight	Approx. 1.4 Kg	

3. Mechanical installation dimensions diagram

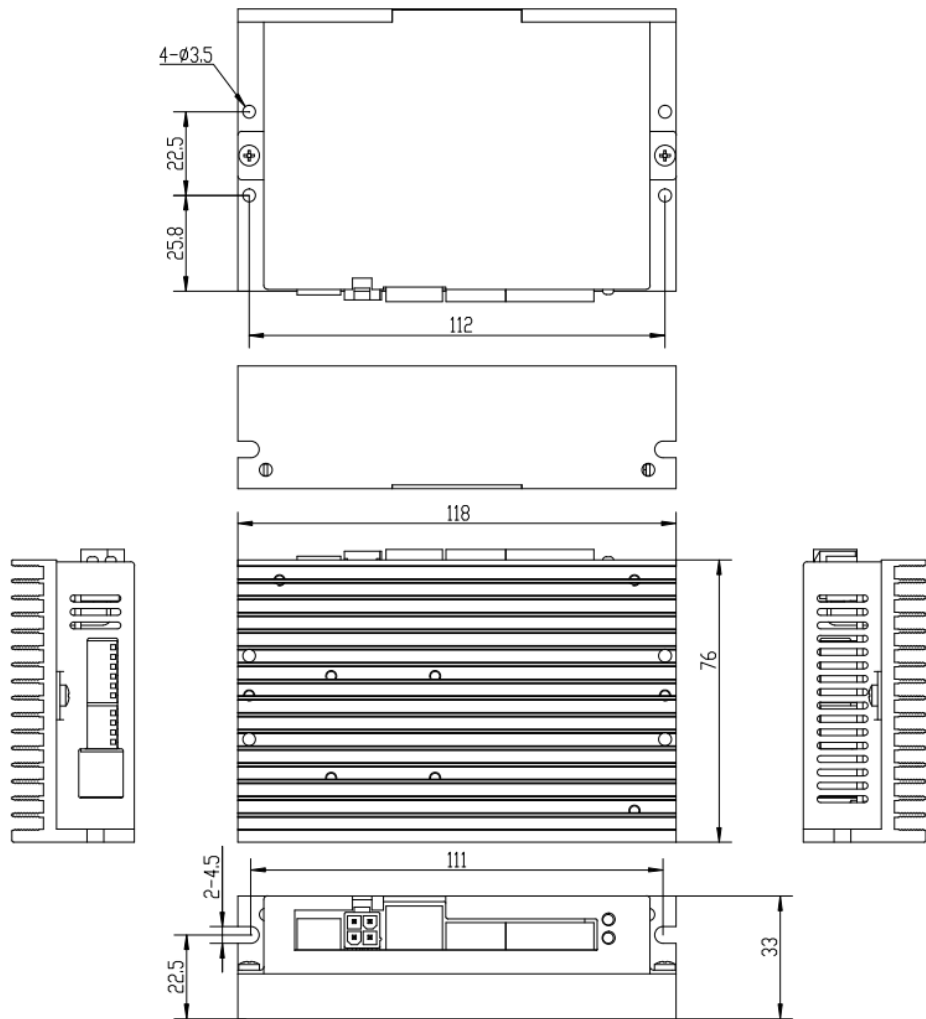

Picture1 Mechanical Installation Dimensions Diagram

4. Heat dissipation considerations

Driver's reliable working temperature should be within 60°C, and motor working temperature should be within 80°C; When installing the driver, please use the upright side installation to form strong air convection on the surface of the radiator. If necessary, install the fan near the driver and use forced cooling method to cool the system to ensure that the drivers operate in a reliable operating temperature range.

III. Driver Interface and Wiring Introduction

1. Interface description

1.1 Control signal and power input interface definition

Pin Number	Signal	Function	Description
1	PU+	Pulse signal input positive	Compatible with 4,5V~28V level signals
2	PU-	Pulse signal input negative	
3	DR+	Direction signal input positive	
4	DR-	Direction signal input negative	
5	MF+	Enable signal input positive	Common-cathode OC output signal, The port can source maximum 100mA /24V. PEND/Z function can be set by dial-up.
6	MF-	Enable signal input negative	
7	ALM	Alarm signal input positive	
8	PEND/Z	PEND/Z signal output	
9	BRK	Brake signal output positive	
10	COM-	Common signal output negative	

1.2 Power port

Pin Number	Signal	Function Description
1	V-	Power Ground
2	V+	Power Supply Input(Positive)(24~50Vdc)

1.3 Encode Port

Pin Number	Signal	Function Description
1	PE	Encoder grounded shield input, Reserved
2-4	NC	Reserved
5	+5V	Driver +5V output to power encoder
6	GND	Driver signal ground output to power encoder
7	EZ+	Encoder channel Z+ input
8	EZ-	Encoder channel Z- input
9	EB+	Encoder channel B+ input
10	EB-	Encoder channel B- input
11	EA+	Encoder channel A+ input
12	EA-	Encoder channel A- input



1.4 RS232 communication port

Special RS232 cable (Prohibition of charging plug) and serial port adapter board which is provided separately, or will be attached randomly depending on the user's situation are designed to setup communication between the driver and PC-based configuration & tuning software ProTuner. The PC software is used to set driver's functions and parameters, such as the peak current, Micro-step, pulse active level, current loop parameters, and so on.

Pin	Symbol	Name
1	TDO	TDO of chip
2	TXD	RS232 transmit
3	RXD	RS232 receive
4	GND	Ground

1.5 LED status indicator

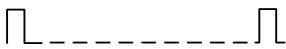
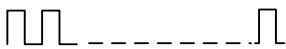
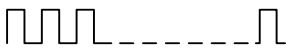
The green LED turns on when the driver is powered on and functions normally. When driver is powered off, the green LED is off. The red LED blinks periodically (in every 5 seconds) to indicate the different error type. When the fault is cleared by the user, the red LED is always off. The blink frequency of red LED is 2Hz. In each blink, red light is on for 200ms and then off for 300ms. The specific relationship is shown in the following table.

Priority	Time(s) of Blink	Sequence wave of Red LED	Description
1	1		Over current fault
2	2		Over voltage fault
3	3		Under voltage fault
4	5		Position following fault

2. Control signal interface circuit

The control signal interface of driver can be divided into input signal and output signal. Input signal interface is differential signal input. According to customer needs, as shown in the following picture, the connection can be done by the differential connection method, the common-anode connection method and the common-cathode connection method.. It has also built-in high-speed opto-coupler. Output signal interface is transistor open-collection output. Only common-cathode connection can be used for output signal interface.

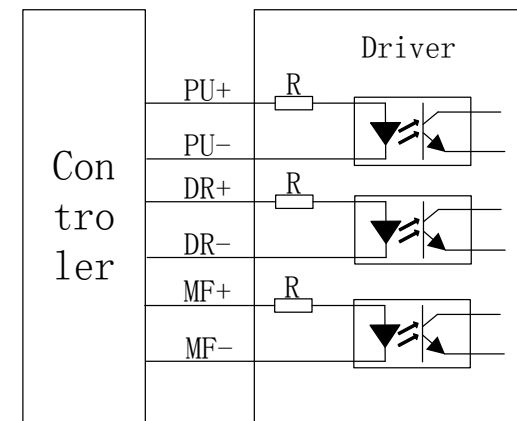

Picture 2 Input signal differential connection method

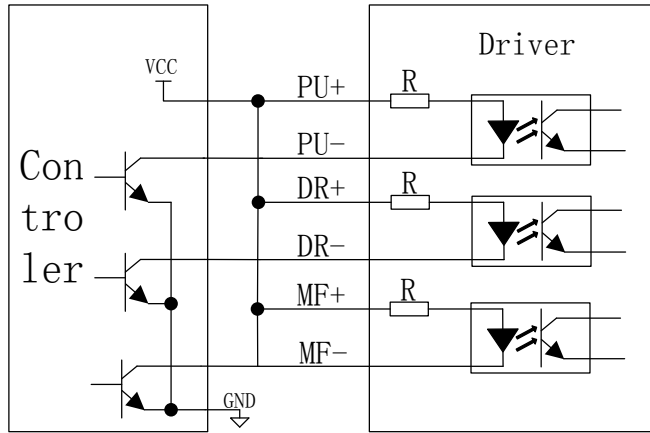

Picture 3 Input signal common-anode connection method

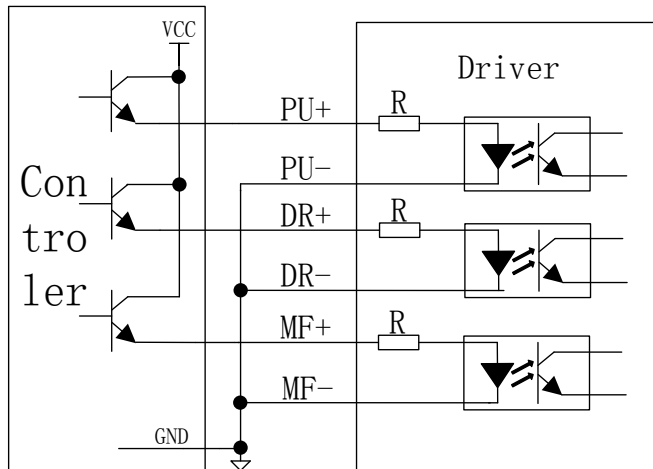

Picture 4 Input signal common-cathode connection method

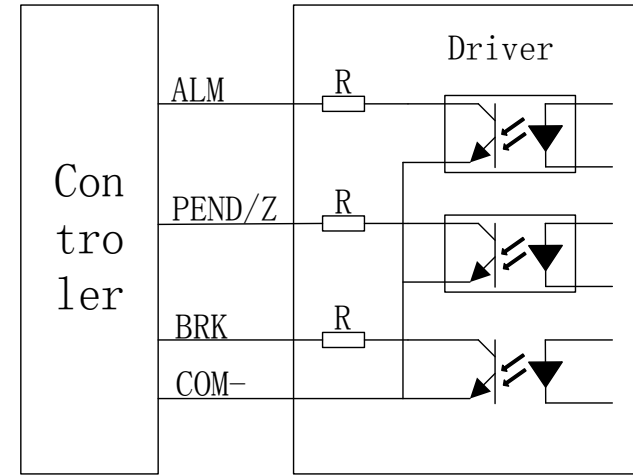

Picture 5 Output signal common-cathode connection method

Note: The signal input interface voltage range in the picture is 4.5V~28Vdc, No matter it is the common-anode and common-cathode connection or differential connection, series current limiting resistor is not needed.

The output interface with the maximum capacity of pull-up voltage 28Vdc and output current 100mA. Select suitable pull-up resistor according to external pull-up voltage. If the external pull-up voltage is 24Vdc, the pull-up resistor is 2K. If the external pull-up voltage is 12Vdc, the pull-up resistor is 1K.

3. Sequence chart of control signals

In order to avoid some fault operations and deviations, PU, DR, MF should meet some rules, as shown in the following picture,

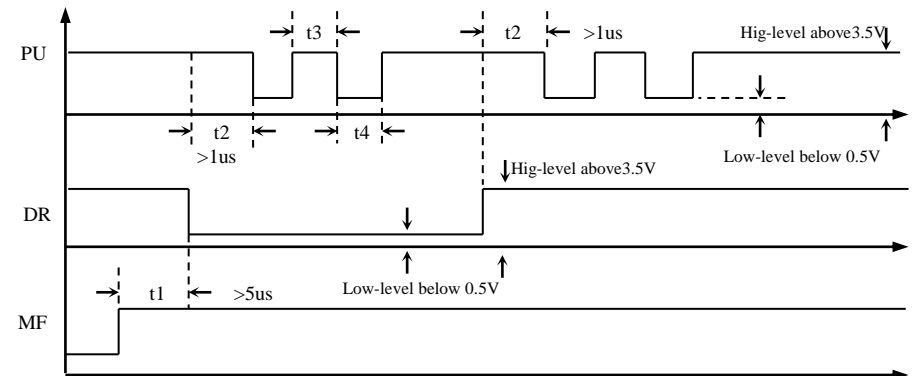

Note:

- 1) t1: MF must be ahead of DR by at least 5us, Usually, By default this signal is left **UNCONNECTED & ENABLE** .
- 2) t2: DR must be ahead of PU effective edge by at least 1us to ensure correct direction.
- 3) t3: Pulse width not less than 1.5us;
- 4) t4: Low level width not less than 1.5us.

4. Wire connection

- 1) In order to improve anti-interference performance of the driver, it is recommended to use twisted pair shield cable, and the shield is shorted to ground, Except for special requirements, the shielded wire of the control signal cable is also shorted to single-ended ground. The upper end of the shielded wire is grounded, and the driver end is unconnected. Only allowed on the same point grounding in the same machine, If it is not a real ground wire, the interference may be serious, and the shielding layer is not connected at the time. If conditions permit, thermal grounding is most effective for shielding.
- 2) To prevent noise incurred in PU/DR signal, pulse/direction signal wires and motor wires should not be tied up together. It is better to separate them by at least 10 cm, otherwise the noise generated by motor will easily disturb pulse direction signals, causing motor position error, system instability and other failures.
- 3) If a power supply serves several drivers, separately parallel connecting the drivers is recommended instead of daisy-chaining.
- 4) It is prohibited to pull and plug power connector while the driver is powered ON, because there is high current flowing through motor coils (even when motor is at standstill). Pulling or plugging power connector with power on will cause extremely high back-EMF voltage surge, which may damage the driver.
- 5) It is strictly forbidden to add lead to the terminal after adding tin, otherwise the terminal may be damaged due to the increased contact resistance.
- 6) Lug must not be exposed outside the terminal to prevent accidental short circuit and damage to the driver.

IV .DIP Switch Configurations

Pulse Type Closed-loop Stepper Driver adopts 10 bit dial switch to set single and double pulse, motor direction, open and closed loop selection, smoothing filter time, Micro-step, etc. The detailed description is as follows:

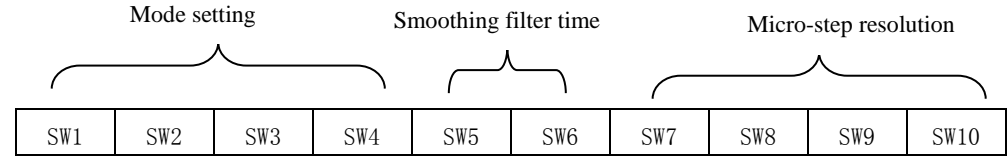

Picture 7 Dialing Schematic Diagram

SW1 sets single and double pulse. When OFF, the single pulse is effective; When ON, the double pulse is effective.

SW2 sets the default motor direction. When OFF, counterclockwise (CCW) direction; When ON, clockwise (CW) direction.

SW3 sets the control mode. When is OFF, closed-loop mode; When ON, open loop mode.

SW4 sets PEND/Z output function selection. When OFF, position output; When ON, Z signal output.

SW5、SW6 set the drive smoothing filter time.

Filter Time	SW5	SW6
Default	OFF	OFF
3ms	OFF	ON
12ms	ON	OFF
40ms	ON	ON

Note: Smoothing filter time can also be customized according to customer needs.

Micro-step dial-up SW1、SW2、SW3、SW4: as shown in the following Micro-step dial-up chart. Customers can set the desired Micro-step by dial-up. When SW1、SW2、SW3、SW4 are ON together, it can be changed into any Micro-step required by the customer through the upper computer.

Pulse/rev	SW7	SW8	SW9	SW10
Default	ON	ON	ON	ON
800	OFF	ON	ON	ON
1600	ON	OFF	ON	ON
3200	OFF	OFF	On	ON
6400	ON	ON	OFF	ON
12800	OFF	ON	OFF	ON
25600	ON	OFF	OFF	ON
51200	OFF	OFF	OFF	ON
1000	ON	ON	ON	OFF
2000	OFF	ON	ON	OFF

4000	ON	OFF	ON	OFF
5000	OFF	OFF	ON	OFF
8000	ON	ON	OFF	OFF
10000	OFF	ON	OFF	OFF
20000	ON	OFF	OFF	OFF
40000	OFF	OFF	OFF	OFF

V. Brake Motor Connection Method

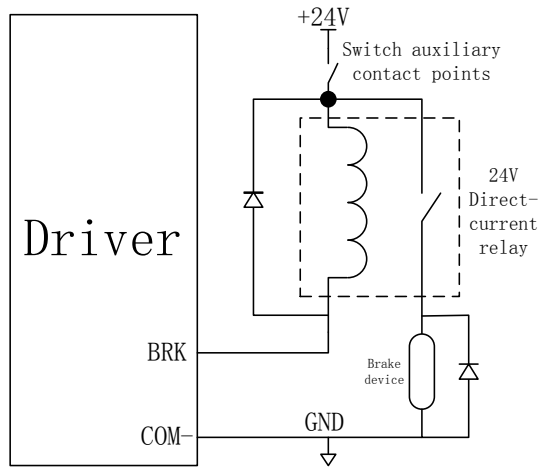

Picture 8 Schematic diagram of brake motor connection method

Because the brake coil and relay coil are inductive loads, It is recommended to add a diode to absorb the back electromotive force generated at the moment of turning off. The diode polarity must not be reversed. The connection method of brake motor is shown in the picture.

VI. Common Problems and Solutions

When the drive fails and makes alarm, the fault can be judged by the number of flashing lights. Over-current is unrecoverable fault. If this fault still exists after power on again, please check whether the wiring has short circuit. Over-voltage and under-voltage are recoverable fault. Alarm will be restored when the fault is restored or the power is reenergized. Position following fault alarm can be eliminated by MF or be restored by power-on again.

For other common problems and solutions, please refer to the following table.

Symptoms	Possible Problems	Solution
Motor is not rotating	No Power	Check the power supply circuit for normal power supply
	The motor shaft is strong.	Control pulse signal is too weak. Increase signal current to 7~16mA.
	Micro-step resolution is too small.	Select the right micro-step resolution setting
	Drive is protected.	Power on again
	Enable signal is low.	Pull up or do not connect Enable signal.
	Do not respond to Input control signals.	Not powered.
	Voltage is too high or too low.	Check Power Supply
	Motor or driver is damaged.	Replace motor or driver
Inaccurate location	Control signal is disturbed	Eliminate interference
	Grounded shield is not connected well or disconnect	Reliable grounding.
	Open winding of motor	Check motor wire
	Micro-step resolution setting is wrong.	Select the right micro-step resolution setting.
Motor stalls during acceleration	Acceleration is set too high	Reduce the acceleration
	Motor torque is insufficient for the application.	Choose another motor with higher torque
	Voltage is too low.	Properly increase voltage.

Product Warranty Terms

1. Twelve month limited warranty

Changzhou Fulling Motor Co, Ltd. Warranties its products against defects in materials and workmanship for a period of 12 months from date of delivery. During the warranty period, Fulling Motor will either, at its option, repair or replace products which proved to be defective for free.

2. Exclusions

The above warranty does not extend to any product damaged by reasons of improper or inadequate handlings by customer.

1) Improper or inadequate customer wiring; For example, the positive and negative poles of the power supply are connected in reverse, or the electric plug and pull are charged.

2) Unauthorized modification or misuse;

3) Operation beyond the electrical specifications of the product and/or operation beyond environmental specifications for the product;

4) Poor ambient heat dissipation.

3 Obtaining warranty service

If your product fails during the warranty period,

1) You need to obtain a returned material authorization number before returning product for service.

2) Please enclose a written description together with the goods. The description shows driver's fault phenomenon, the voltage, current, operating environment or more when the fault occurs, contact name, telephone number and address and so on.

3) Send the goods to Changzhou Fulling Motor Co., Ltd

Address: #69 Kunlun Road, xinbei district, Changzhou City, 213022, China

4 Warranty limitations

1) The warranty coverage of the product is limited to the device and process (i.e. consistency)

2) Fulling motor specifically disclaims the implied warranties of merchantability and fitness for a particular purpose. Because the suitability is also related to the technical indicators of the use, the conditions of the use and environment. We do not recommend the use of this product for clinical purposes.

5 Maintenance requirement

Please fill in the Maintenance Report truthfully when repairing to facilitate maintenance analysis. (This form can be downloaded at www.fullingmotor.com)

Address: #69 Kunlun Road, xinbei district, Changzhou City, 213022, China